

1. Features of the Cam Follower

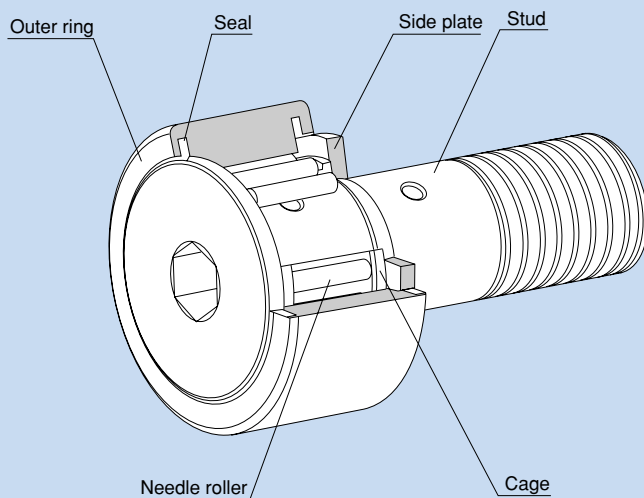

Fig. 1 Structure of Cam Follower Model CF...UU-A

1.1. Structure and Features of the Cam Follower

The Cam Follower is a compact and highly rigid bearing with a shaft. It contains needle bearings and is used as a guide roller for cam mechanisms or linear motion.

Since its outer ring rotates while keeping direct contact with the mating surface, this product is thick-walled and designed to bear an impact load.

Inside the outer ring, needle rollers and a precision cage are incorporated. This prevents the product from skewing and achieves a superb rotation performance. And, as a result, the product is capable of easily withstanding high-speed rotation.

There are two types of the outer ring in shape: spherical and cylindrical. The spherical outer ring easily absorbs a distortion of the shaft center when the cam follower is installed and helps lighten a biased load. The Cam Follower is used in a wide range of applications such as cam mechanisms of automatic machines, dedicated machines as well as carrier systems, conveyors, bookbinding machines, tool changers of machining centers, pallet changers, automatic coating machines, sliding forks of automatic warehouses.

1.2. Types and Features of the Cam Follower

● Popular Type Cam Follower Model CF

It is a popular type of Cam Follower provided with a driver groove on the head of the stud. A highly corrosion resistant stainless steel type (symbol M) is also available.



Model CF

● Cam Follower with a Hexagon Socket Model CF-A

Since the stud head has a hexagon socket, this model can easily be installed using a hexagon wrench.

A type whose stud screw has a hexagon socket (CF-B) is also available (applicable to stud diameter of 12 or greater).



Model CF-A

● Eccentric Cam Follower with a Hexagon Socket Model CFH-A

This model can be installed in the same mounting hole as that of model CF. Since the mounting shaft of the stud and the stud head are eccentric by 0.25 mm to 1.0 mm, the position of this model can easily be adjusted simply by turning the stud. Thus, it is a compact, highly accurate eccentric cam follower with an integral structure. As a result, the man-hours for machining and assembly can significantly be reduced because it is unnecessary to align the cam follower with the cam groove and machine the mounting-hole area with precision.

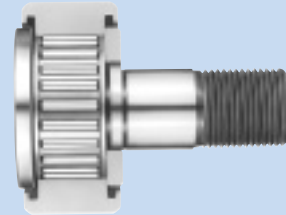

Model CFH-A

● Cam Follower Containing Thrust Balls Model CFN

Based on the popular type Cam Follower, this model is incorporated with thrust load balls. Model CFN is capable of receiving an axial load generated due to a mounting error.



Model CFN

● Cam Follower with a Tapped Hole for Greasing Model CFT

Basically the same as the popular type Cam Follower, this model is provided with tapped holes for piping on the stud head and the thread.

It is optimal for locations where an integrated piping for greasing is required.

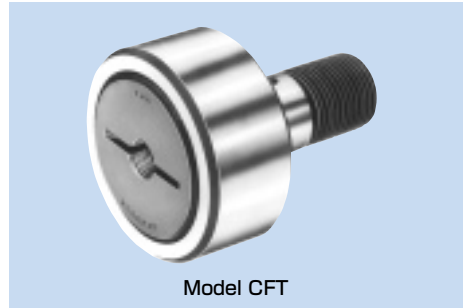

Model CFT

1.3. Types and Model Numbers of the Cam Follower

The Cam Follower is divided into several types as indicated in table 1.

Table 1 Types and Model Numbers of Cam Followers

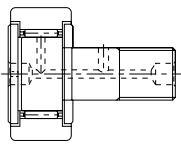
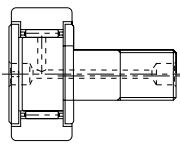
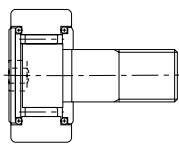
Type		Popular type	Eccentric Cam Follower	Containing thrust balls
Shape				
Cylindrical outer ring	Stud with a hexagon socket	CF-A (CF...UU-A)	CFH-A (CFH...UU-A)	-----
	Stud with a driver groove	CF (CF...UU)	CFH (CFH...UU)	-----
	With a tapped hole for greasing	CFT (CFT...UU)	CFHT (CFHT...UU)	-----
	Made of stainless steel	CF-M (CF...MUU)	CFH-M (CFH...MUU)	-----
Spherical outer ring	Stud with a hexagon socket	CF-R-A (CF...UUR-A)	CFH-R-A (CFH...UUR-A)	CFN-R-A
	Stud with a driver groove	CF-R (CF...UUR)	CFH-R (CFH...UUR)	-----
	With a tapped hole for greasing	CFT-R (CFT...UUR)	CFHT-R (CFHT...UUR)	-----
	Made of stainless steel	CF-MR (CF...MUUR)	CFH-MR (CFH...MUUR)	-----

Note 1: The symbols in the parentheses indicate model numbers of types with seals.

Note 2: THK also manufactures low-speed full-roller types with long service lives. For these full-roller types, symbol "V" is indicated.

Note 3: Symbol M indicates a stainless steel type.

Example : **CF 12 V UUR**

└─ Full-roller type

1.4. Rated Life

Static Safety Factor

The basic static load rating C_0 refers to the static load with constant direction and magnitude, under which the sum of the permanent deformation of the roller and the permanent deformation of the raceway accounts for 0.0001 times of the roller's diameter in the contact area where the maximum stress is applied (if the deformation exceeds this level, it will affect the rotation). This value is indicated as " C_0 " in the dimensional tables in the "THK General Catalog - Product Specifications," provided separately. When a load is statically or dynamically applied, it is necessary to consider the static safety factor as shown below.

$$\frac{C_0}{P_0} = f_s$$

where

- f_s : Static safety factor in relation to C_0 (see table 2)
 C_0 : Basic static load rating (kN)
 P_0 : Radial load (kN)

The permissible load (F_0) indicates the permissible value of the applied load determined by the strength of the stud section of the Cam Follower. Therefore, it is necessary to consider the static safety factor f_M against F_0 as well as f_s .

$$\frac{F_0}{P_0} = f_M$$

where

- f_M : Static safety factor in relation to F_0 (see table 2)
 F_0 : Permissible load (kN)
 P_0 : Radial load (kN)

Table 2 Static Safety Factor (f_s , f_M)

Load conditions	Lower limit of f_s and f_M
Normal load	1 to 2
Impact load	2 to 3

Rated Life

The service life of the Cam Follower is obtained from the following equation.

$$L = \left(\frac{f_r \cdot C}{f_w \cdot P_c} \right)^{\frac{10}{3}} \times 10^6$$

where

L : Rated life

(The total number of revolutions that 90% of a group of identical Cam Follower units independently operating under the same conditions can achieve without showing flaking from rolling fatigue)

C : Basic dynamic load rating* (kN)

P_c : Radial load (kN)

f_r : Temperature factor (see Fig. 2)

f_w : Load factor (see table 3)

* Note: The basic dynamic load rating (C) of the Cam Follower shows the load with constant direction and magnitude, under which the rated life (L) is 1 million revolutions when a group of identical Cam Follower units independently operate. The basic dynamic load rating (C) is indicated in the corresponding dimensional table in the "THK General Catalog - Product Specifications," provided separately.

Calculating the Service Life Time

When the rated life (L) has been obtained, the service life time (L_h) is obtained from the following equation.

● For Linear Motion

$$L_h = \frac{D \cdot \pi \cdot L}{2 \times \ell_s \cdot n_1 \times 60}$$

where

L_h : Service life time (h)

L : Rated life

D : Bearing outer diameter (mm)

ℓ_s : Stroke length (mm)

n₁ : Reciprocations per minute (min⁻¹)

● For Rotary Motion

$$L_h = \frac{D \cdot L \times 10^6}{D_1 \cdot n \times 60}$$

where

D₁ : Outer ring contact average diameter of the cam (mm)

n : Rotation speed per minute of the cam (min⁻¹)

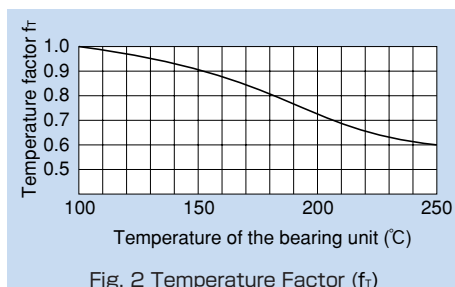

Note: The normal service temperature is 80°C or below. If the product is to be used at a higher temperature, contact THK.

Table 3 Load Factor (f_w)

Service condition	f _w
Smooth motion without impact	1 to 1.2
Normal motion	1.2 to 1.5
Motion with severe impact	1.5 to 3

1.5. Accuracy Standards

Cam Followers are manufactured with accuracies according to table 4.

- ① Dimensional tolerance of the cylindrical outer ring in outer diameter D : table 4
- ② Dimensional tolerance of the spherical outer ring in outer diameter D : $-\overset{0}{0.05}$
- ③ Dimensional tolerance of the Cam Follower in stud diameter d : h7
- ④ Dimensional tolerance of the outer ring in width B : $-\overset{0}{0.12}$

Table 4 Accuracy of the Outer Ring (JIS Class O)

Unit: μm

Nominal dimension of the bearing outer diameter (D) (mm)		Tolerance of the bearing in outer diameter (Dm) ^(note)		Tolerance of the outer ring in radial run-out (max)
Above	Or less	Upper	Lower	
6	18	0	- 8	15
18	30	0	- 9	15
30	50	0	-11	20
50	80	0	-13	25
80	120	0	-15	35

Note: "Dm" represents the arithmetic average of the maximum and minimum diameters obtained in measuring the bearing outer diameter at two points.

1.6. Track Load Capacity

The track load capacity means the permissible load at which the outer ring of a bearing and the mating surface are capable of withstanding repeated use over a long period. The track load capacity provided in the dimensional table in the "THK General Catalog - Product Specifications," provided separately, indicates the value when using a steel material with tensile strength of 1.24 kN/mm² as the mating material. Therefore, it is possible to increase the track load capacity by increasing the hardness of the material. Fig. 3 shows the hardness of the mating material and the track

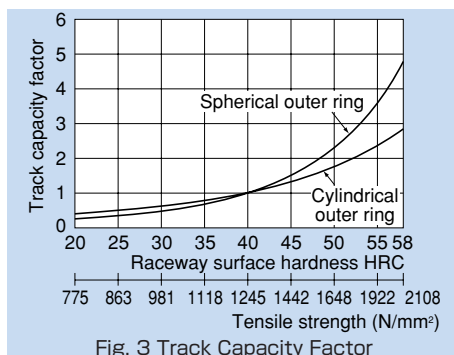

Fig. 3 Track Capacity Factor

capacity factor in relation to tensile strength. To obtain the track load capacity of each mating material, multiply the track load capacity shown in the corresponding dimensional table in the "THK General Catalog - Product Specifications," provided separately, by the respective track load factor.

Note: For the mating material, we recommend using those materials with the raceway hardness of 20 HRC or higher and the tensile strength of 775 N/mm² or higher.

[Example of calculating a track load capacity]

Obtain the track load capacity when heat-treating the mating material, which a bearing whose outer ring has a track load capacity of 5.29 kN contacts, to hardness of 50 HRC. The track capacity factor when the hardness is 50 HRC is 2.32, as indicated in Fig. 3. Therefore, the desired track load capacity is calculated as follows.

$$\text{The track load capacity} = 5.29 \text{ kN} \times 2.32 = 12.3 \text{ kN}$$

1.7. Radial Clearance

The radial clearances of Cam Followers meet clearance C2 (see table 5).

(Normal clearance applies to full-roller types.)

Table 5 Radial Clearance

Unit: μm

Model No.: CF, CFN, CFH and CFT	Clearance C2	
	Min.	Max.
3 to 4	3	17
5 to 8	5	20
10 to 12 - 1	5	25
16 to 20 - 1	10	30
24 to 30 - 2	10	40

1.8. Fitting

For the dimensional tolerance of the Cam Follower in stud-mounting hole, we recommend the following fitting.

The dimensional tolerance of the stud-mounting hole: H7

1.9. Dust Prevention and Lubrication

The Cam Follower models include seal types (model numbers: "...UU"), which are incorporated with special synthetic rubber seals that are highly resistant to wear in order to prevent foreign matter from entering the interior of the cam follower and the lubricant from leaking.

Since each Cam Follower unit with seals contains high-quality lithium soap group grease No. 2, you can start using the product without replenishing grease.

If your Cam Follower does not have seals, fill grease from the greasing hole on the stud or the inner ring. However, some of the model numbers with stud diameters of 10 mm or less do not have a greasing hole and are provided with initial lubrication only, and therefore do not allow replenishment of grease.

The appropriate fill quantity is a half to one third of the space inside the bearing. The lubrication interval varies depending on the operating conditions. As a guide, however, replenish grease of the same group every six months to two years for types with a cage, or every one to 6 months for full-roller types.

Even with types equipped with seals ("...UU"), surplus grease may seep during the initial operation period or immediately after grease replenishment. If desiring to avoid contamination of the surrounding area of the machine by grease, first perform seasoning or the like in advance, and then wipe the seeping surplus grease.